

# MODELLING AND SIMULATION OF HYBRID (WIND and SOLAR) FOR DC MICROGRID

S.Priya

*PG Student, Dept Of EEE,*

Saranathan College Of Engineering, Trichy,

E-Mail-priyamalathy13gmail.com

M.Marimuthu,

*Assistance prof, Dept Of EEE,*

Saranathan College Of Engineering, Trichy,

E-Mail-marimuthuoffice@gmail.com

S.Vijayalakshimi

*Associate prof, Dept Of EEE,*

Saranathan College Of Engineering, Trichy,

E-Mail-bksvijji@gmail.com

S. Prassanna Perumal,

*PG Student, Dept Of EEE,*

Saranathan College Of Engineering, Trichy,

E-Mail-prassannaex@gmail.com

## ABSTRACT:

This paper deals with the development of DC Micro grid using Hybrid Wind/Solar power system using MATLAB/SIMULINK. The hybrid of small modular device such as PV, small wind turbine and storage device and it given to DC load is known as DC microgrid. Wind/Solar hybrid power system is used to improve the energy efficiency and the LED'S are useful for power cost. LED'S are energy saving, high luminous efficiency and very much useful life. LED (Light Emitting Diode) street light system play an major role and run in DC power with the increased use of Hybrid power system, Since the irradiance of pv panel and speed of the wind turbine is variable this is controlled by power electronics device. Here buck and boost converter is used for both the energy. The proposed system was canvas in consider to the operation status of the hybrid input power and battery voltage using MATLAB simulation. The hybrid system is determined by simulating using MATLAB/SIMULINK.

**Keywords:** (Solar, Wind, Boost and Buck Converter, MPPT and PID controller, DC Microgrid)

## I. INTRODUCTION

In present day a huge problem in many countries is power demand, so we move to Renewable energy that we integrated the solar and wind energy. The global insight of renewable energy in power system is rapidly increasing for wind and solar energy system. Amount of solar power and wind power integration increases it can

be created technical challenges to the grid Power system due to solar and wind power is naturally sporadic. The size of the battery storage energy belong to intermittency level of the solar or wind .In summation if solar or wind are used to supply the power to a stand-alone system, energy storage system becomes essential to assure that power supply is continuous.

## A. WIND ENERGY

The popular field of technology is wind energy so it has many developments laying ahead the wind power industry is one of the fastest expanding industries as a result of rapid growth of installed capacity. In Fig.1 depicts the generation of Power using Windmill. This is the renewable energy sources for taken from wind mill. The generation of electricity from wind energy has less installation and maintenance. We can produce the energy almost 24 hours of the day. Initial cost also less for this kind of system.

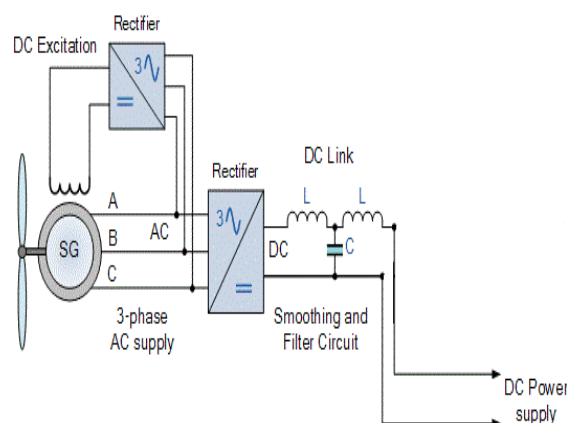
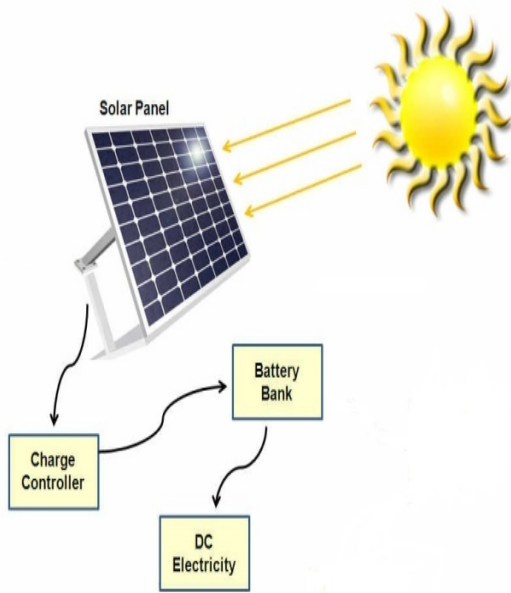

Fig. 1 Generation of power using Wind mill

**B. SOLAR ENERGY**

The unlimited source of energy is originated from the sun. In Fig. 2 shows the light and heat from the sun are used directly without any changing and it used by converting the form of solar energy. This is the direct way to harvest the easy energy. There is several way of connecting the gained electricity with the existing grid. Nowadays renewable energy techniques for power production are mature and reliable. The Photo Voltaic (PV) energy is the most promising source of energy since it is pollution free and abundantly available everywhere in the world. PV energy is especially beneficial in remote sites like deserts or rural zones where the difficulties to transport fuel and the lack of energy grid lines make the use of conventional resources impossible.



**Fig. 2 Power from Solar Energy**

This propose work of the paper to plan the hybrid power system in four main strategise as solar system, wind system, MPPT and PID controller, and battery charging are been performance and maintenance. The development system has been canvas in regard to operation characteristics through MATLAB/ SIMULINK.

**II. SYSTEM DESCRIPTION AND MODELLING**

The configuration scheme of hybrid system for LED Street lighting application is shown in fig 3. A DC-DC converter is used to buck the higher voltage DC for wind and boost the lower voltage DC for solar and stored in the battery used to LED

street lighting. In this section the dynamic simulation model is described for pv/wind turbine hybrid generation system . The developed system consists of PV, Boost converter in one section and wind turbine ,PMSM, ac/dc rectifier and buck converter in another section and stored in battery bank. The block diagram of the developed system is shown in fig 3.

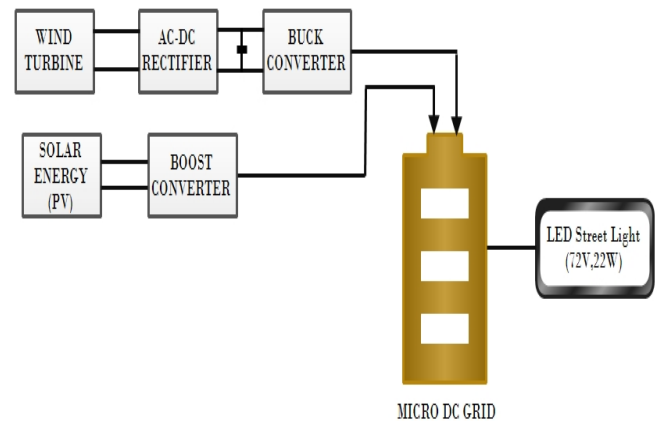

**Fig3. Hybrid wind and solar**

**III WIND ENERGY SYSTEM**

Wind turbines work by turning the kinetic energy of the wind into torque that causes the wind turbine to turn and drives an electrical generator. The wind is made up of real matter with mass, when mass is moving it has kinetic energy. Wind turbine in this microgrid simulation study is modelled by an aerodynamic input torque with drives a wind generation. The wind generator considered here is a gearless direct driven PMSM.

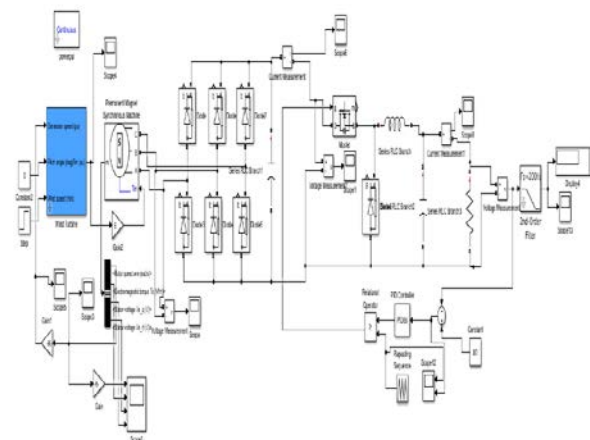

**Fig 4 Simulation of wind conversion**

Due to the variations in wind speed, the output power of the wind turbine PMSG experiences

variations in frequency and amplitude, By maintain the constant voltage and improve the efficiency of wind turbine is amend by PID controller. A controller suitable for DC-DC converter must match with their nonlinearity and input voltage and load variations, ensuring stability in any operating condition. The values of  $K_p$ ,  $K_i$  and  $K_d$  are obtained using the above procedure for the given buck converter and the values obtained are  $K_p=0.001$ ;  $K_i=49.7859$ ;  $K_d=5.0215e^{-7}$  it shown fig

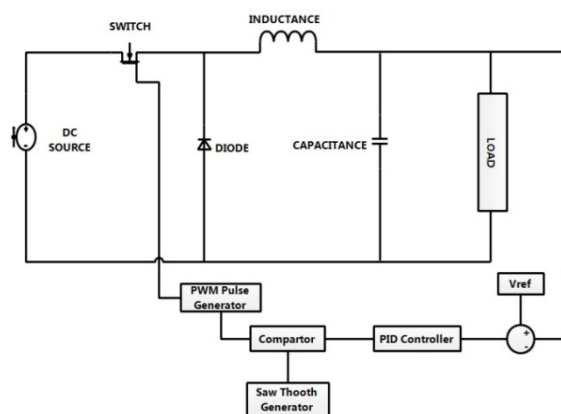

**Fig 5 Buck converter with PID**

As regard, the power converter the buck converter is used to step-down the DC voltage it has buck to 80V. The buck converter were designed with MOSFET ( $V_s=424V$ ,  $I=2.46A$ ,  $R=172\Omega$ ). The proposed model is implemented is shown in fig 5.

#### IV SOLAR ENERGY MODEL

Photovoltaics is the method of converting solar energy into direct current electricity using semiconductor materials which exhibit photovoltaic effect PV model represent solar irradiance and temperature changes which may happen during the day. The PV system model is controlled so that it is operated at its MPP. PV power generation employs solar panels composed of a number of solar cell containing a PV power generation employs solar panels composed of a number of solar cells containing a PV material. The material used for photovoltaic including monocrystallinesilicon, amorphous silicon. Photovoltaics power capacity is measured as maximum power output under standardized test condition. Therefore it cannot be interfaced directly to the load. The output of solar panel is

DC is connected to the boost converter to boost the voltage. This constant DC output is stored in battery.

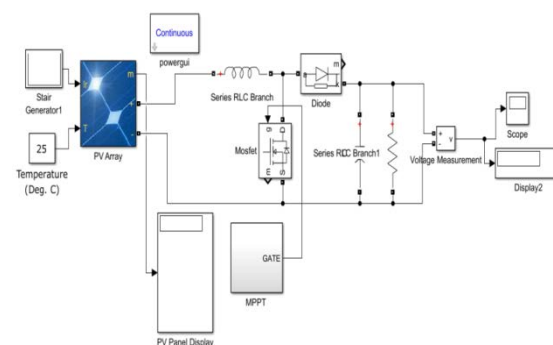

**Fig 6 Simulation of solar conversion**

As already later, the MPPT system is obligated to improve and extract the maximum power from solar panel. The output feature of the solar module has different solar irradiance and temperature are non-linear. Moreover the solar irradiation is undeterminable, which make the MPP of the PV module changes continuously. Hence there are different techniques of MPPT is need to operate the solar panel as its maximum power point (MPP). Perturb and observe algorithm is maximum power point tracking (MPPT) control algorithm that will be modified in this model. The flow chart shown in fig [7]. An MPPT controller model is improved and applies using MATLAB, to operate the PV model at its maximum power point. The p&o algorithm requires two measurements one is current and other is voltage. Thus in the following discussion some parameter are asset for the MPPT system according [9][10]. As regards the power converter a boost converter is used as tracker, shown fig[6].The boost converter is widely used in MPPT system [9][10]. To set-up the PV voltage to higher DC voltage, it boost to 80V, the design of converter as( $V_s=58V$ ,  $I_a=22A$ ,  $R=5\Omega$ ). The proposed model is implemented as shown in fig [6].

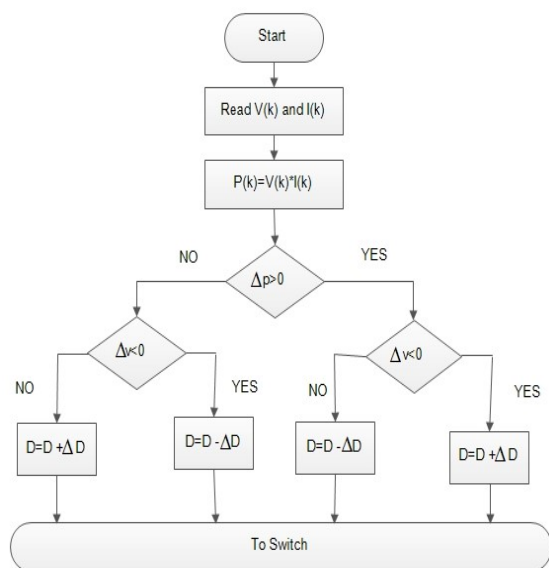

**Fig 7 Flow chart of P&O algorithm**

### V ENERGY STORAGE SYSTEM BATTERY

A lithium – ion battery is a member of family of rechargeable battery type in which lithium ion move from the negative electrode to the positive electrode during discharge and back when charging. The parameters of the battery of storage capacity 12[V]/150[Ah] battery. The battery is the most common method of energy storage in standalone systems.

### VI SIMULATION OF HYBRID POWER SYSTEM

The complete system design of the hybrid input/ output analysis of the proposed system was simulated by MATLAB/SIMULINK, the battery bank is designed, The simulated of hybrid wind, solar and battery as in fig[7], then load as been resistive load. The characteristics of the proposed system were analyzed by changing these element, which the wind and solar energy system as maintain the constant 77V.

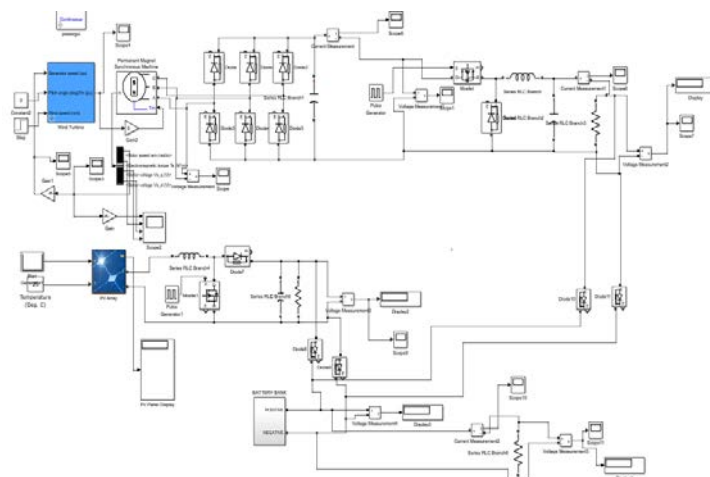

**fig 8 Simulation of hybrid wind – solar**

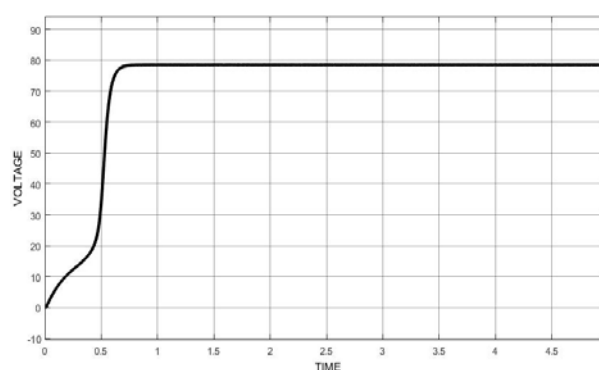

**Fig 9 Simulation output of wind conversion**

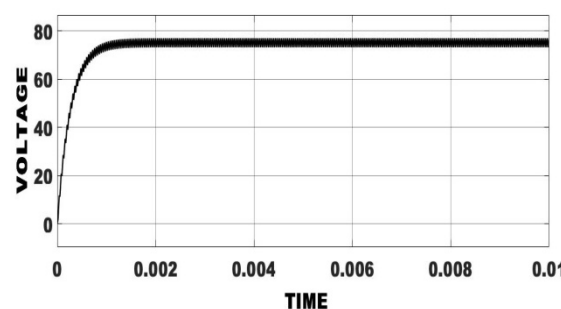

**Fig 10 Simulation output of solar conversion**

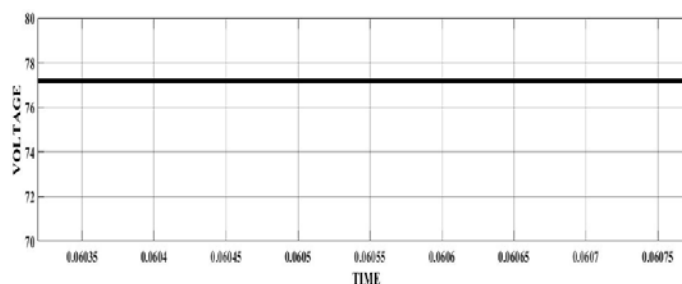

**Fig 9 Simulation of hybrid power maintain 77V**

## VII CONCLUSION

In this paper a SIMULINK model of the hybrid wind and solar power generation system is proposed. Rapidly changing irradiance and wind energy variation are considered in this paper. The considered hybrid is equipped with an energy storage system and connected to the load. In this paper it analysis the MPPT controller for solar energy and PID controller for wind energy. Wind Solar-hybrid power system is simulated using MATLAB / SIMULINK.

## REFERENCE

1. Bogdanms.borowy, ziyad m.salamesh” methodology for optimally sizing the combination of a battery bank and pv array in a wind/pv hybrid system” *iee transactions on energy conversion*, vol. 11, no. 2, june 1996
2. Daniel I. Meier “Standalone Solar Generation With LED Floodlights for Outdoor Sign Illumination.
3. Hammad Abo-Zied Mohammed “ Design and implementational of a photovoltaic system used for street LIGHTS.
4. Kai strunz, ehsan abbasi, and duc nguyen huu” DC Micro Grid for wind and solar power ntegration” *iee journal of emerging and selected topics in power electronics*, vol. 2, no. 1, march 2014
5. K. Pavankumar Reddy , M. Venu Gopal Rao “Modelling and simulation of Hybrid wind solar energy system using MPPT, *Indian Journal of science and Technology*.
6. Meei songkang, "Generation cost assessment of an isolated power system with a fuzzy wind power generation model", *iee transactions on energy conversion*, vol. 22, no. 2, page(s): 397 - 404, June 2007.
7. P.sandeep, dr.m.gopichand naik,” modelling and operation of micro grid with wind and photovoltaic resources (*international research journal of engineering and technology (irjet)*)
8. Rashmika chin chamalatpure, s. s. mahajan “wind and solar power integration for microgrid with low power fluctuations using super capacitor” *international journal of industrial electronics and electrical engineering*, issn: 2347-6982 volume-3, issue-4, april-2015
9. Rupesh s.patil, prof.ashok jhala , prof. manish prajapati “ review paper for grid integration of hybrid generation, *international research journal of engineering and technology (irjet)* volume: 03 issue: 09 | sep -2016
10. S. Selvam edison prabhu . k bharath kumar m.r andrew mathew dominic” solar and wind hybrid power generation system for street lights at highways” *international journal of science, engineering and technology research (ijsetr)*, volume 3, issue 3, march 2014
11. T.sato and t.tanabert, "generation scheduling for wind power generation by storage battery system and meteorological forecas", *iee conference on power and energy society general meeting - conversion and delivery*, page(s): 1 - 7, 20- 24 july 2008.
12. Wei qiao, *member, ieee*, anuj sharma, jerry l. hudson, *fellow, ieee*, elizabeth g. jones, and laurence rilet wind/solar hybrid generation-based roadway Micro Grids.
13. Yong-sik Lee , Jae-Hyeon Gim “ Development of LED street lighting controller for wind-solar hybrid power system.